

Piezoelectric film (PVDF) ultrasound transmitters offer unique advantages for air ranging applications. Cylindrical 40kHz PVDF transmitters exhibit omni-directional horizontal beam directivity and broad band characteristics. These characteristics lend unique solutions in many applications such as two-dimensional positioning, digitizer, object detection, and distance measurement. Depending on the applications, resonance frequency and vertical beam directivity of the transmitter can easily be customized by changing the diameter and length of the PVDF cylinder. PVDF transmitters also have very low resonance Q value. Typically, PVDF transmitters have a Q value of 5. This means that the rising time and the signal decay time are much faster than the conventional ceramic transmitters. This characteristic is suitable for high speed data acquisition or high speed digitizer applications. Also, a test board, consisting of snap-in mounting holes and test pins, is available for easy evaluation of 40kHz transmitters.

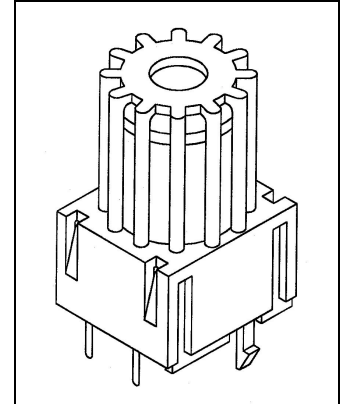

CHARACTERISTICS

- Omni-directional horizontal beam directivity
- Broad band
- Low resonance Q
- Excellent impact resistance
- Low cost
- Light weight

	Part #	Model #
40kHz Transmitter	1005853-1	US40KT-01
Test Board	1005854-1	US40KM-01
Drive Electronics	1005855-1	USDE-01

APPLICATIONS

Two dimensional position detection, digitizer, distance measurement, object detection, and general purpose air ranging applications.

SPECIFICATIONS ⁽¹⁾

PVDF Thickness:	30 μm
Resonance Frequency:	40 kHz
Bandwidth:	8 kHz
Resonance Q:	5 ⁽²⁾
Sound pressure output:	0.025 Pa/Vp
	107 dB/200 Vp ⁽³⁾
Horizontal beam directivity:	360°
Vertical beam directivity:	±40° ⁽⁴⁾
Capacitance:	1200 pF
Drive Voltage:	max 300 Vp ⁽⁵⁾
	max 150 Vp ⁽⁶⁾

ENVIRONMENTAL CHARACTERISTICS

Storage Temperature:	-20°C - +85°C
Operating Temperature:	+5°C - +60°C

- (1) Values are Typical
- (2) Resonance Q may vary depending on transmitter housing design
- (3) 0dB = 2×10^{-4} μbar (20 μPa) @30cm distance
- (4) at -6dB
- (5) For burst drive
- (6) For continuous drive

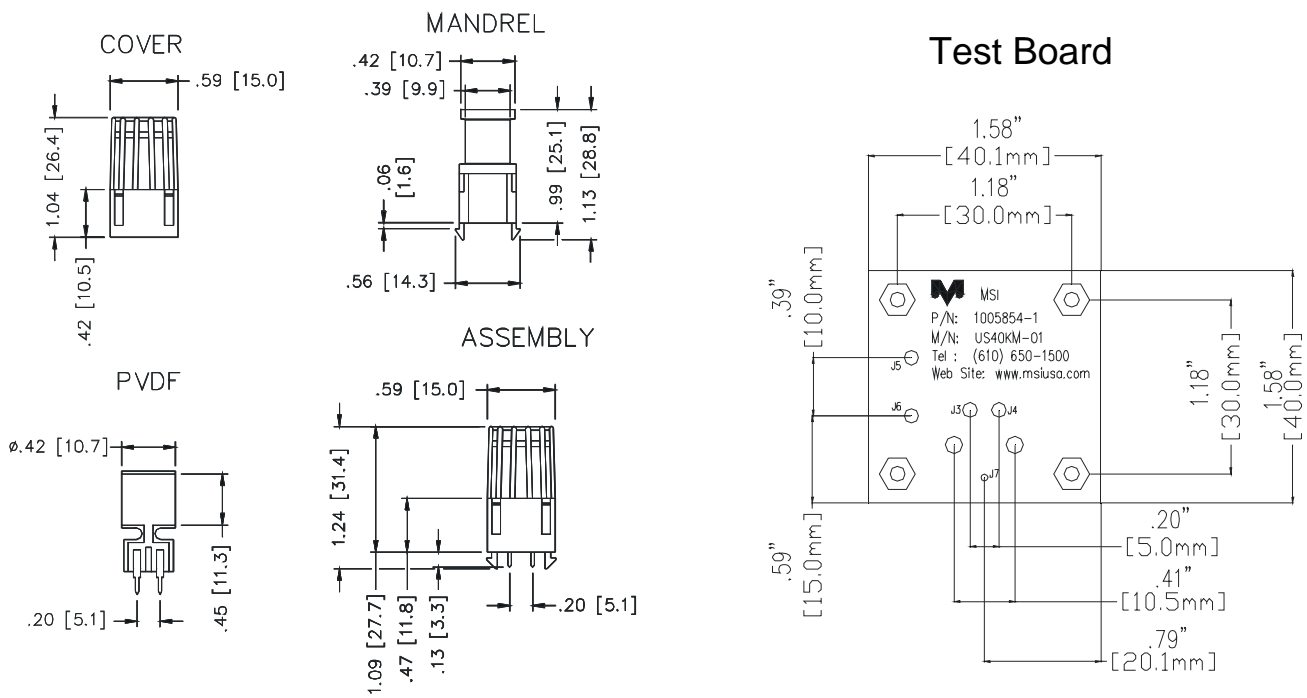
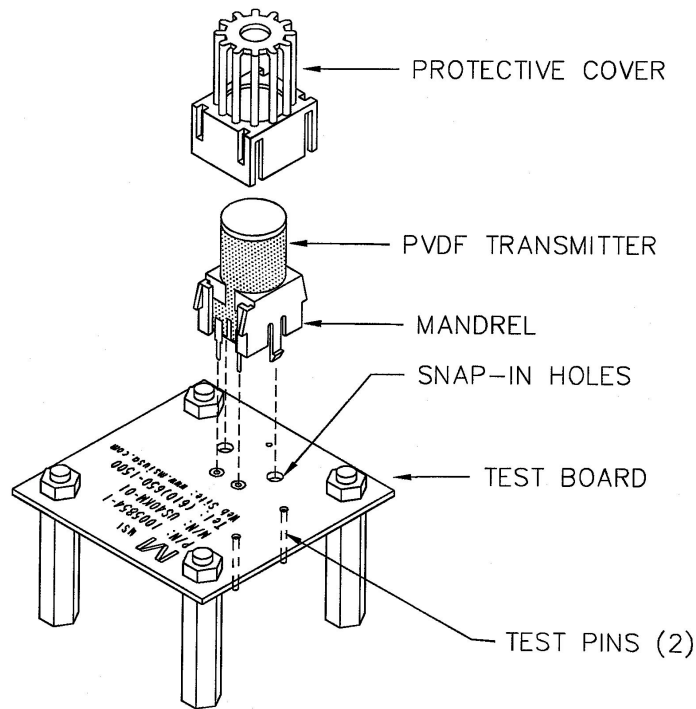

TYPICAL FREQUENCY RESPONSE

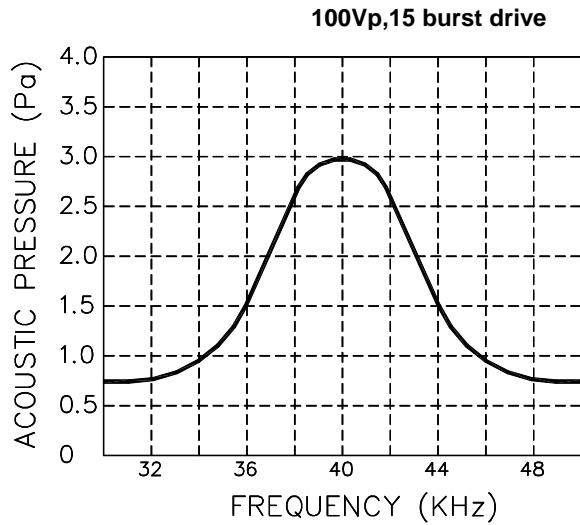

TYPICAL TIME RESPONSE

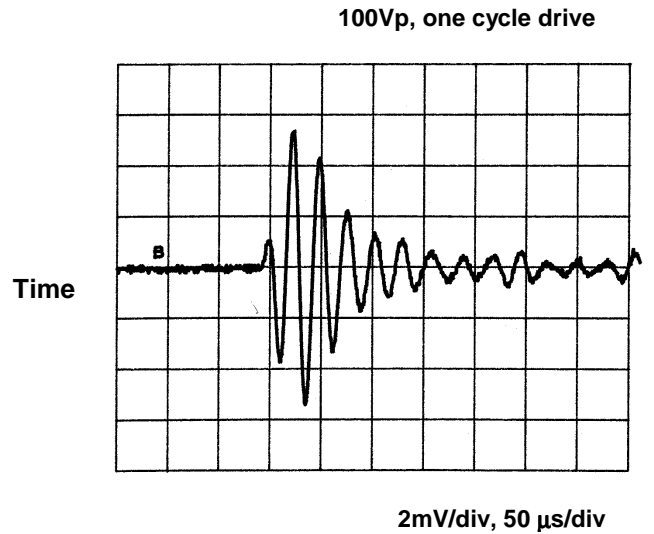

TYPICAL HORIZONTAL BEAM DIRECTIVITY

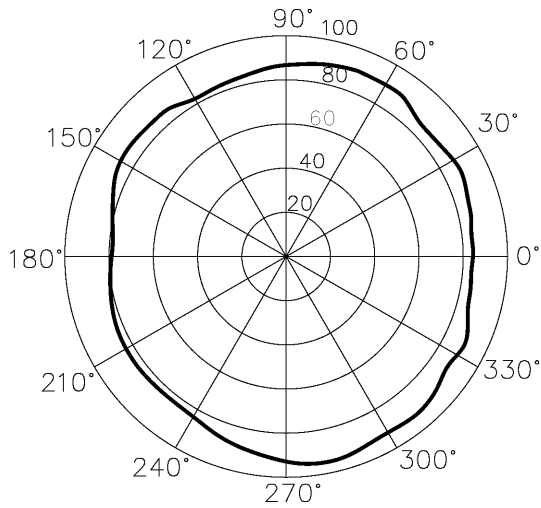

TYPICAL VERTICAL BEAM DIRECTIVITY

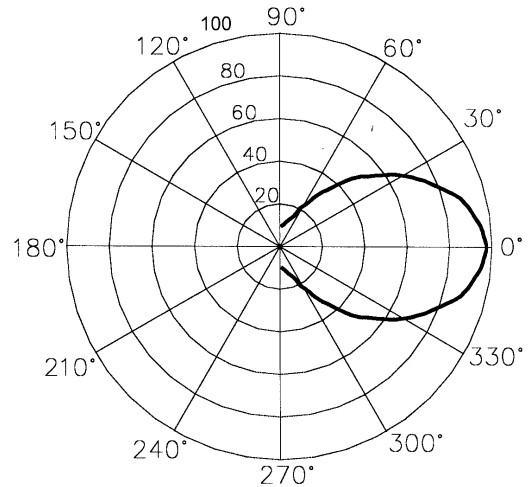

PVDF Lead Attachment – PVDF lead design can be customized depending on the transmitter housing design and the circuit board design. For lead attachment, either rivets or solder tabs can be used.

Typical Drive Circuit – Maximum system efficiency can be achieved when the drive electrical resonance frequency matches the mechanical resonance frequency. Since the equivalent circuit of PVDF transmitters is capacitance, a transformer or a series inductor can be used to create the electrical resonance. A drive circuit example is shown below. When the PVDF transmitter is operated at a continuous mode, it is recommended that the drive voltage not exceed 150V_p.

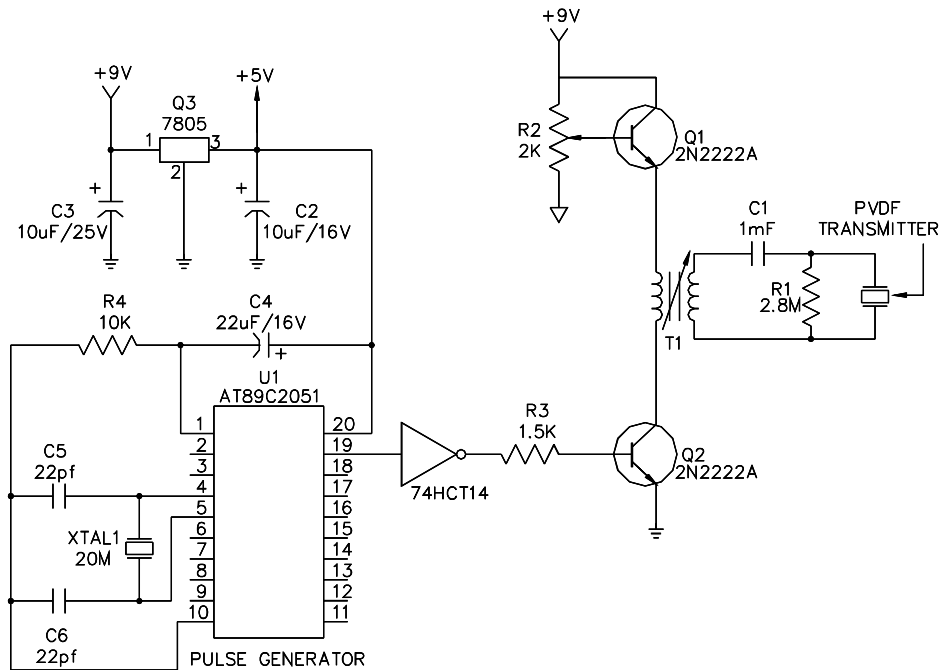

Drive electronics are designed to drive 40kHz PVDF transmitters with a selectable number of burst. The number of burst may be selected depending on the applications. A single pulse drive signal is recommended for distance measurement applications such as ultrasound digitizers. A 12 or higher burst drive signal can be used to maximize the detectable distance for object detection applications.

Part Number: 1005855-1
Model Number: USDE-01

SPECIFICATIONS

	Min	Typ	Max	Unit
Supply Voltage	10	12	15	VDC
Supply Current	0.07	0.12	0.16	ADC
Frequency		40		kHz
Output Voltage*	300	350	360	Vp-p
Burst	1		20	Cycle
Storage Temperature	-20		85	°C
Operating Temperature	5		65	°C

*With PVDF transmitter load

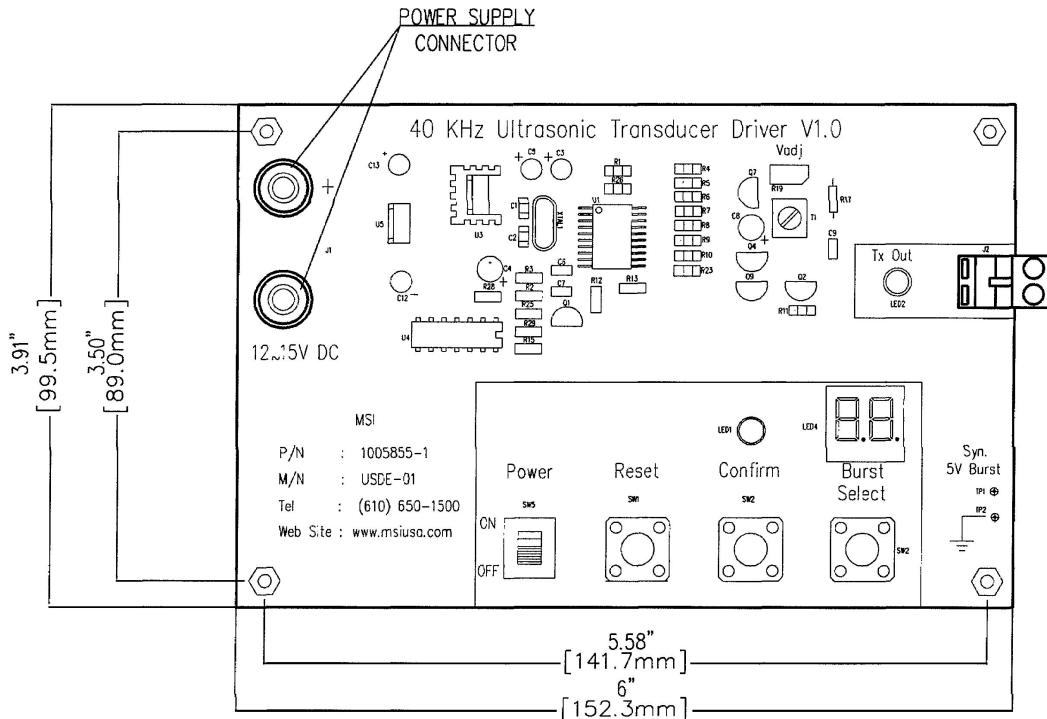

Layout

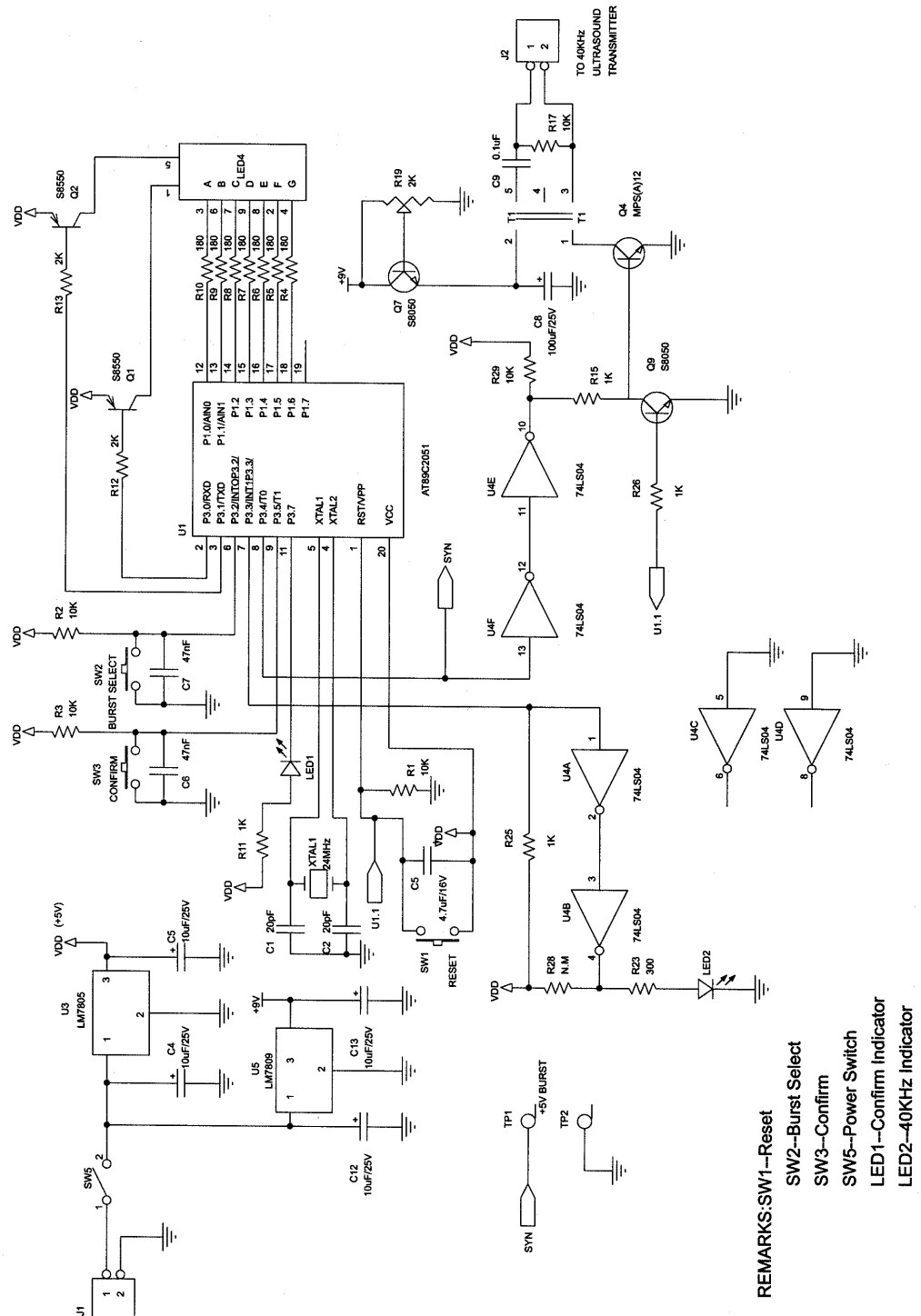

- REMARKS:**
- SW1—Reset
 - SW2—Burst Select
 - SW3—Confirm
 - SW5—Power Switch
 - LED1—Confirm Indicator
 - LED2—40KHz Indicator

Circuit Diagram